

PV Source based Multi Area Interconnected Efficient Power System

Ravi Kumar Prajapati^{*1}, Anjana Tripathi², Balram Yadav³

¹ M.Tech Student, School of Electrical & Electronics Engineering, Scope Global Skills University, Bhopal M.P.

ramchakrabati@gmail.com¹

² Assistant Professor, School of Electrical & Electronics Engineering, Scope Global Skills University, Bhopal, M.P.

anjana.tripathi2210@gmail.com²

³ HOS, School of Electrical & Electronics Engineering, Scope Global Skills University, Bhopal, M.P.

balram@sgsuuniversity.ac.in³

ABSTRACT

The continuous increase in power demand leads to the attraction of alternative green energy sources. Photo Voltaic (PV) power generation is one of the most promising renewable green energy technologies used as an alternative source of power. The integration of PV to the load requires the support of power electronic converter for performance enhancement. The complications in power electronics converters are rapidly evolving, as their applications are extensively used with the stand-alone/grid-based systems.

The power electronics is essential for harnessing energy from solar, wind and other green energy sources. As the power developed by photovoltaic (PV) system is DC, to convert it into AC power converters are required. Similarly, to convert wind energy a high efficient generator is required. Also power converters helps to improve waveform in terms of reduce harmonics and good power factor.

Key words- Photovoltaic System, Automatic Generation Control, MPPT

1. INTRODUCTION

The advancement of innovation throughout the years, particularly the advance of power electronics applications, has achieved numerous specialized comforts and prudent benefits; however it has at the same time made new difficulties for power system operation concern. Driven by testing ecological requirements, advancement of the energy market and privatization of the power supply industry, power systems are increasingly working at their maximal execution limits - and every now and again past them - to expand resource use. To dodge genuine utilitarian issues from happening under these conditions, the system's safe and dependable activity should be kept up with respect to different parts of power system task. One of the principle themes of unique concern is the part of power quality which manages, among others, voltage characteristics, current characteristics and in particular control and forecast of harmonics.

Since the nature of electrical power, e.g. the voltage provided by the utility or the client infused current, has turned into a critical component, the enthusiasm for finding, portraying or more all, in estimating system conduct develops consistently. The broad utilization of power electronic loads in distribution networks requests substitute techniques to

figure power quality issues previously they happen keeping in mind the end goal to keep up solid system task. Routinely, power distribution systems are designed to work with unadulterated sinusoidal waveforms and electric utilities endeavor to meet this prerequisite. However, the nearness of harmonics in the power system speaks to a risk to touchy types of gear like adjustable speed drives, power electronic loads, PCs and so forth. All the while, amid their typical activity, these types of gear acquaint distortion with the consistent state current and voltages. These conditions have set the reason for giving careful consideration to the nature of electrical power and tending to the issue of voltage and current harmonic distortion. Endeavours to establish relentless state harmonic points of confinement as guidelines for electrical systems containing power gadgets or other nonlinear loads developed as a plausible arrangement. Gauges force confinements on harmonic currents which thusly impact the voltage waveform. Harmonics are an important quantifiable parameter of power quality. The related financial parts of harmonics and deregulation have all made a requirement for broad observing of the power system harmonics. Clients with delicate types of gear utilize harmonic current observing to find the wellspring of harmonic related issues that may happen. On the opposite side, utilities endeavour to meet the requests of their clients: they screen the supply voltage to demonstrate that the nature of the offered power is inside the pre-indicated benchmarks and to acquire the fundamental data for taking care of issues. The utility additionally maintains whatever authority is needed to gauge the measure of the client's harmonic current infusion whenever. These estimations are generally spot checks to find harmonic sources. At long last, deregulation makes a testing and aggressive new condition, where power quality is a parameter which should be estimated and checked consistently.

Prateek et al. [1], the combination of non-traditional energy sources like breeze energy for conservative activity isn't simply expanding the size of the advanced power framework yet in addition the intricacy in satisfying the heap need. The topology suggested in (AbderezakLashab et al. [2]) comprises of a combination of three-level (3L) active neutral-point-clamped inverter and floating capacitor connected parallel to the legs of H-bridge. Cascading five-level diode clamped MLI with seven level or 9 level conventional Cascaded H Bridge (CHB) Multilevel Inverters (MLI) results in hybrid topology (A. Lashab et al., [3]) for generating 11-level / 13-level respectively. A new symmetric structure for cascade multilevel converter is developed in (Q. Huang et al., [4]) which is composed of several series-connected switched capacitor diode units and an H-Bridge inverter for polarity reversal. MLI structure using a cascade connection of sub multilevel inverter by (M. Abarzadeh et al., [5]). A. Lashabet et al. [6], in this work, the near-state pulse width modulation (NSPWM), adjusted to be utilized as a part of dual-voltage source inverter (VSI) fed open-end load, is acquainted essentially pointing with obviously limit the voltage add up to harmonic distortion (THD).

1.1 POWER QUALITY

Power quality for the most part manages the interaction among the clients and the utility or it can be likewise said that it gives an interaction between the power system and the separate load. A definitive objective of power system is the supply of electric energy to its clients. Over the most recent 50 years or somewhere in the vicinity, as a result of the broad development of enterprises power request has massively expanded which has prompted establishment of

numerous power generation and distribution grid. The interest for expansive measure of power for modern and local utilize expanded the weight on the generation. Electrical utilities working today are functioning as a subsystem of a vast utility network that are entwined with a specific end goal to shape an unpredictable grid. Every one of these factors have put the power system under the necessity of a power quality. A powerful quality is the primary point of the business facility design, alongside "prosperity," "trustable administration" and "low start and working costs". Issue in power quality is generally alluded to any electrical issue faced in the frequency, voltage or current deviation which prompts mal-activity of the client's equipment. Frequently when we discuss nature of power we actually mean the nature of voltage since it is the voltage which is controlled the greater part of the circumstances. The term power quality can be connected with dependability of the system by the electrical utilities. The most troublesome thing is upkeep of the electrical power quality so it will exist in as far as possible. There are numerous drawbacks of poor and low power quality. It might prompt higher power losses, anomalous and uncommon conduct of electrical hardware, and impedance with the adjacent correspondence lines, poor voltage profile, harmonics, hang and swells in the voltage, poor and low distortion and displacement factor [7].

In the current time power electronic and electronic hardware are winding up increasingly touchy when contrasted with their partners couple of years back. The hardware which is especially defenceless to this variety or debasement of power quality is the delicate loads. Unadulterated sinusoidal voltage is required for its legitimate task. Alongside the expanded affectability of the gear, the developing affectability of organizations towards the creation loss on account of diminishment in the edge of benefit has likewise included to the weight the nature of power. From ages power has been considered as an essential right in the household life and it will dependably be there. Because of this very reason even a little intrusion in the supply prompts overwhelming grievances, regardless of whether no harms are identified with it [8].

Tripping of the electrical equipment on account of aggravations in the supply voltage is as often as possible depicted by customers as "horrendous power quality". Then again utilities regularly observe agitating impacts on account of the end customer hardware as the standard power quality issue. The inconvenience in assessing power quality concerns is elucidated by the method for interaction among the nature of power and the gear. What is "incredible" power quality for one gear could be "terrible" power for another. Two unclear gear may react differently to a similar power quality parameters due to contrasts in their gathering. Present day electronic gear isn't in charge of voltage agitating impacts; it moreover causes aggravations for various buyers. The principle guilty party behind this poor power quality is the utilization of power electronic devices that are for the most part the gear driven by converters and rectifiers like PC, speed drives and so forth that acts as non-direct load [9, 10].

1.2 INTERCONNECTED POWER SYSTEMS

From a practical viewpoint, the problems of frequency control of interconnected areas are more important than those of isolated (single) areas. However, for understanding the theory and concept of an interconnected system, the knowledge of single area is equally important. Practically all power systems today are tied together with neighboring areas and the problem of automatic generation control becomes a joint undertaking. Following are the basic operating principles of an interconnection of power systems [11].

1. Under normal operating conditions, each control area should strive to carry its own load, except such scheduled portions of the other members' loads as have been mutually agreed upon.
2. Each control area must agree upon adopting regulating and control strategies and equipment that are mutually beneficial under both normal and abnormal situations.

2. TWO AREA INTERCONNECTED POWER SYSTEM

As two area interconnected power system connected through a tie line is shown in Figure 1. Each area feeds its control area and tie line allows electric power to flow between the areas.

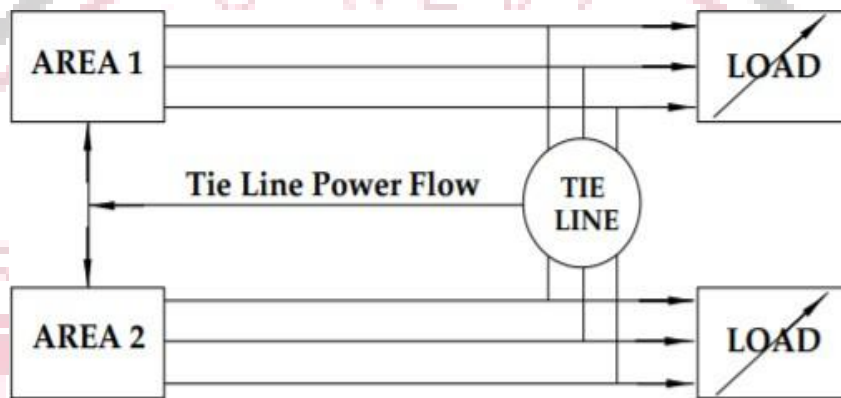

Figure 1: A two area interconnected power system

A single control area is characterized by the same frequency throughout. In other words, the area network is 'rigid' or 'strong'. In the case of a two area system, it is assumed that each area is individually 'strong' and the two areas are connected by a 'weak' tie line. An interconnected power system may consist of any number of subsystems or areas [12].

3. WAVEFORM DISTORTION

It's basically the variety from the sine wave of power frequency. It can be of different sorts as said beneath.

3.1 Harmonics

While providing of a nonlinear load from a supply voltage at the power frequency, these nonlinear load draws currents at in excess of a specific frequency that at long last prompts a mutilated current waveform. These are present or voltage signals having frequencies as far as necessary products of central frequency. Add up to harmonic voltage distortion (THD) is used for estimation of the level of harmonic present in any waveform. THD measures greatness and also phase of each individual harmonic segment. The THD data may in some cases be misdirecting, so with a specific end goal to conquer that another wording has been presented by the IEEE models.

It is known as the aggregate request distortion (TDD). TDD is like THD with the distinction that the harmonics here are communicated as a level of some appraised load current as opposed to a level of crucial current [13, 14, 15].

3.2 Inter Harmonics

These are present or voltages waveforms whose frequency segments are not the whole number different of the typical frequency (i.e.50 or 60 Hz).The hotspots for this between harmonics are arcing devices, cyclo converters and so on. The impact of inter harmonics isn't that unmistakable however it has been seen that they influence power line transporter signaling.

Since the creation of mercury arc rectifier in 1902 to change over rotating current to coordinate current [3], the progressive period of power electronic devices had been begun. Use of mercury circular segment valves in power grids, the high-vacuum and gas-filled diode thermionic rectifiers, activated devices, for example, the thyatron and ignitron were by and large broadly utilized. In the first place, power hardware [7] for the most part centered around propelling devices that give the ability to deal with high power levels. At that point the concentration progressed to the utilization of the semiconductor devices [8] with reasonable power rating to meet more extensive prerequisites of novel items. As of late it was extended to multidisciplinary innovation, for example, counterfeit consciousness and neural network [9].



Figure 2: Electrical Power conversion System

To meet the user requirements, a systematic method was developed to link technical power packaging issues. The framework explores the general power conversion system as delineated in Figure 2. The input powers are handled by the converter as indicated and respect the adapted yield power to supply to the load.

Figure 2 demonstrates the plotted information. if the converter has a productivity of 50 percent, at that point the loss amid the conversion is equivalent to the yield power. This energy is changed over to warm which should be expelled from the converter. In this way a vast and costly cooling process is required for the system. So just expanding the effectiveness can prompt lessening the cost and creating higher yield. So much exertion is given in the converter design procedure to enhance the productivity.

The power electronic conversion process can be one of four types:

1. Alternating current (AC) to direct current(DC)
2. Direct current (DC) to alternating current(DC)
3. Direct current (DC) to direct current(DC)
4. Alternating current (AC) to alternating current(DC)

3.3 Multilevel Inverter Based Z-Source Topology

Three level NPC-MLI based Z-source inverters are very popular in MLI Z-source family. Figure 3 shows 3-level NPC Z-source topologies. These topologies are serving discontinuous input current.

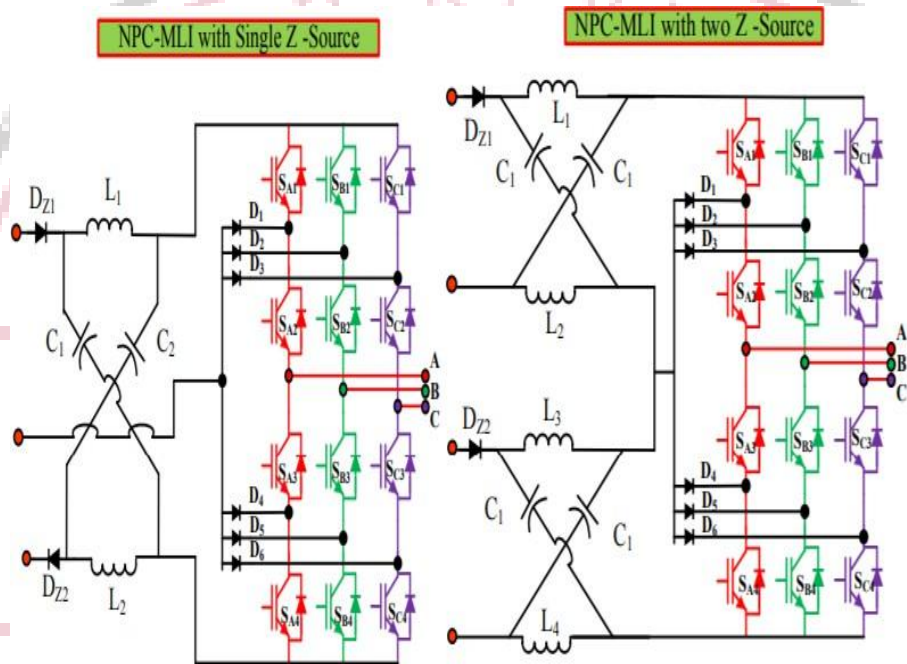

Figure 3: NPC-MLI with Single and two Z-source

The single-stage buck-boost Z-source MLI was first proposed with the extension of the two level conventional Z-source inverter. As compared to the conventional NPCMLI, the two DC source and X network for boosting its input DC-link voltage to higher output voltage. Although it has an idea theoretically feasibility, in terms of low-cost, nevertheless it is not the preminent solution as it habits two-isolated DC input sources and a two X-network (four inductors and four capacitors) which increases the size, weight and cost of the inverter.

Alternatively, the front-end decoupled capacitors are used in two ZS networks with separated input voltage source (VDC) as shown in Figure 4. This topology has higher passive element count; however their inductors and capacitors element are valued smaller.

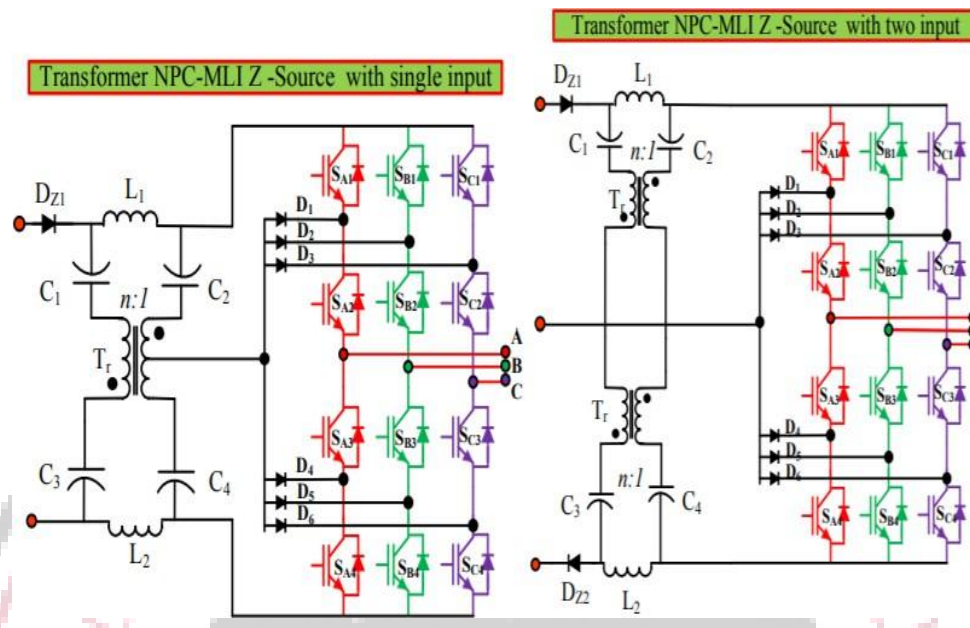

Figure 4: NPC-MLI with Single and two input

4. MODELLING OF PV ARRAY

A photovoltaic system uses one or more solar modules or panels to convert solar energy to electrical energy. Basically, its components include solar panels, mechanical and electrical connections and means of modifying the electrical output we get.

4.1 Photovoltaic Cell

A PV cell is a specially designed pn junction semiconductor device that absorbs the energy of the incident photon and converts it into electrical energy. The concept that the sunlight can be directly converted into electrical energy was first discovered by Edmond Becquerel in 1839. However, the first PN junction PV cell was developed by Dary Chapin, Calvin Fuller, and Gerald Pearson in 1954. It had an efficiency of 6%. Commercially available PV cells are (i) monocrystalline silicon cells, (ii) polycrystalline silicon cells, and (iii) amorphous silicon cells. The monocrystalline silicon cells are made of thin wafers sliced from large single crystals of silicon. The polycrystalline silicon cells are composed of ribbons or wafers containing many silicon crystals fused together, which make them less efficient but also less expensive to produce. The amorphous-silicon cells are made using thin-film technology and therefore they are cheaper as compared to monocrystalline and polycrystalline silicon cells.

4.2 Photovoltaic Module

A PV cell develops an open-circuit voltage in the range of 0.5 to 0.6 volts and a short-circuit current in the range of 2 to 3 amperes. To get adequate voltage, a number of PV cells are connected in series to form a PV module. Normally, the commercially available PV modules develop an open-circuit voltage of 18-20 volts. They are designed to have peak power rating in the range of 35-40 watts. To enhance the power rating of a PV system, a suitable number of PV modules are connected in series and parallel to form a PV array.

4.3 Photovoltaic Array

As the PV array I-V characteristics is a function of solar insolation and ambient temperature, the power developed also changes with the change in the ambient conditions. The cells are characterised normally at a standard insolation of 1 kW/m² or 100 mW/cm² and a temperature of 28° C. These cells are rated in terms of peak watts at the above insolation and temperature. A PV cell is capable of generating approximately 1.5 watts of power.

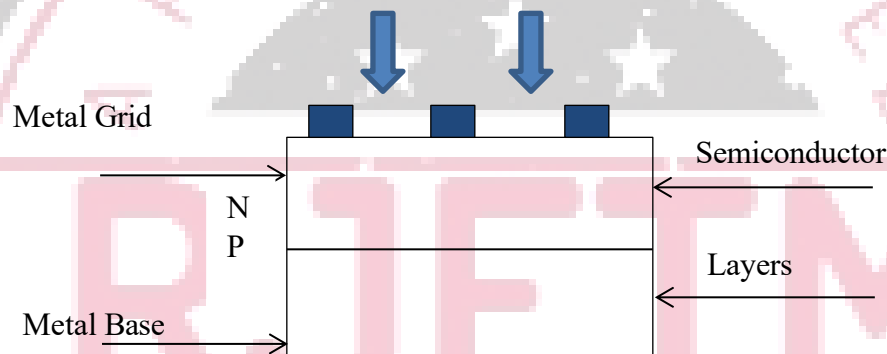

Figure 5: Structure of a PV cell

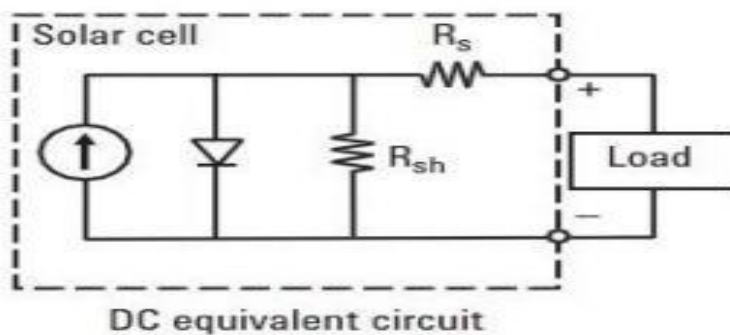

Figure 6: Simplified circuit diagram of a solar PV cell

The photovoltaic cell output voltage is basically a function of the photocurrent which is mainly determined by load current depending on the solar irradiation level during the operation. Figure 5 shows structure of a PV cell and Figure 6 shows simplified circuit diagram of a solar PV cell.

5. MPPT ALGORITHM

The maximum power point (MPP) describes the point on a current voltage (I-V) curve at which the solar PV device generates the largest output i.e. where the product of current intensity (I) and voltage (V) is maximum. The MPP may change due to external factors such as temperature, light conditions and workmanship of the device.

Many maximum power point tracking techniques have been proposed, analyzed and implemented. They can be categorized as:

- [1] Perturb and observation method,
- [2] Incremental conductance method,
- [3] Indirect methods

5.1 Perturb and Observation Method

In perturb and observation (P&O) method the current drawn from the PV array is perturbed after regular intervals by perturbing the duty ratio, d of the dc-dc converter by a factor ΔJ and the resulting output power is compared with that in the previous perturbation cycle. If an increased duty ratio $\{d + \Delta d\}$ results in higher power, it is further increased till the output power begins to decline. On the other hand, if an increase in duty ratio results in lower power than before, then the duty ratio is decreased until power output stops increasing and begins to go down.

5.2 Incremental Conductance Method

Incremental conductance (INC) algorithm is used to overcome the limitations of the P&O algorithm.

5.3 Indirect Methods

Both P&O and INC algorithms, track the true MPP without any knowledge of the I-V characteristics of the PV array. These methods require large computation time to calculate the array power or incremental conductance. In indirect methods, the knowledge of the I-V characteristics of the PV array is utilized to relate the MPP voltage or current to the open-circuit voltage of the PV array, short-circuit current of the PV array, or the load current.

PR controller used to regulate the voltage where output power equals to the sum of proportion and integration coefficients. It provides zero control error and is insensitive to interface of the measurement channel. Simulation diagram of the used PR controller is shown in figure 7.

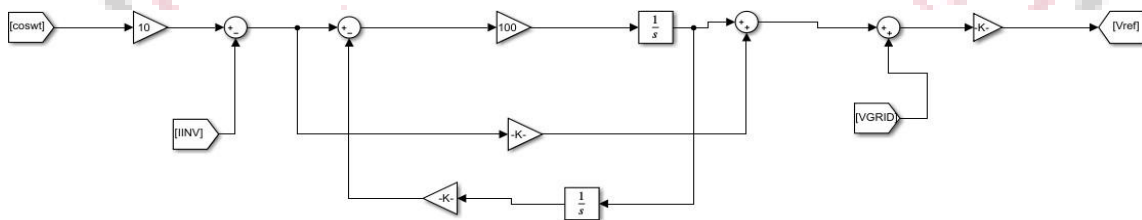

Figure 7: Proportional resonant (PR) controller

The PR Controller disadvantage is slow reaction to disturbances. To adjust the PR Controller, you should first set the integration time equal to zero, and the maximum proportion time. By decreasing the coefficient of proportionality,

achieve periodic oscillations in the system.

In the case of control structure implemented in natural frame, the complexity of the control can be high if an adaptive band hysteresis controller is used for current regulation. A simpler control scheme can be achieved by implementing a dead-beat controller instead. Again, as in the case of stationary frame control, the phase angle information is not a must.

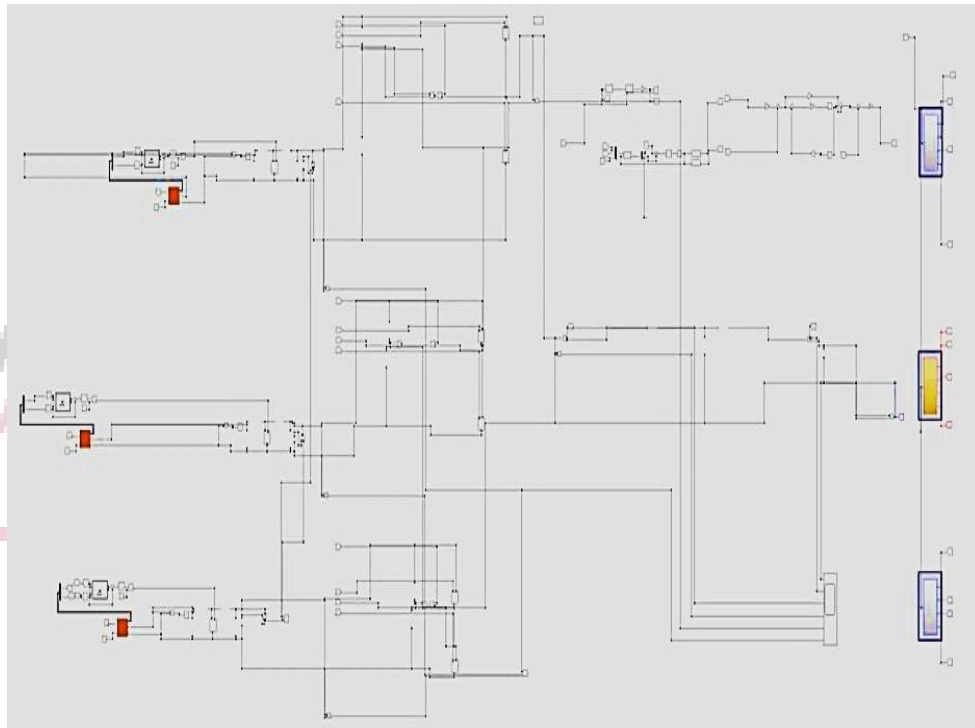

Figure 8: Complete Simulation Model

This work simulates at a 2 KW power rating and use a PV module as 1 parallel and 6 series connected string at specific module. Also, specified 290 maximum dc output voltages. Graph plot of current and power with respect to voltage shown in figure 8.

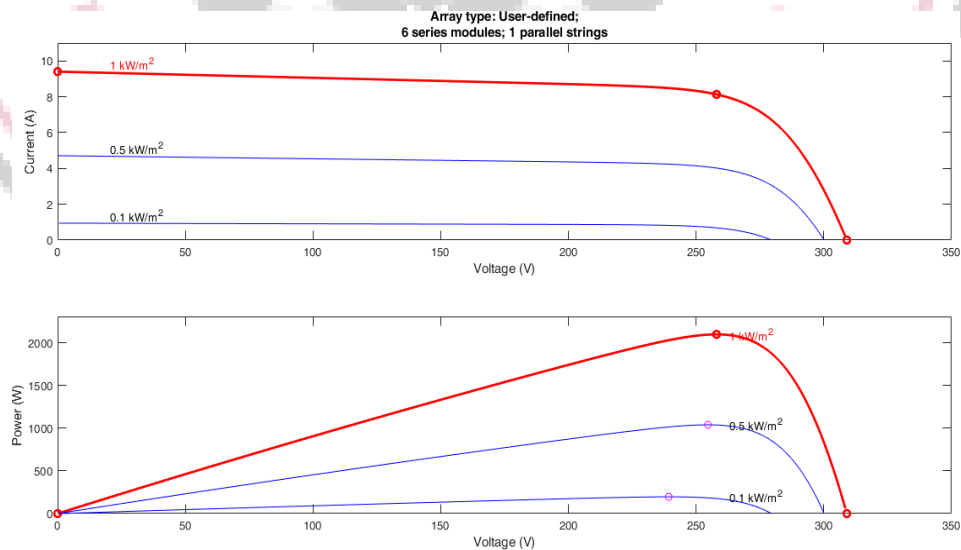

Figure 9: PV power and current with respect to voltage

Maximum PV output voltage is set to 290 according to the PV module and this voltage has approximately 50V peak to peak ripple. This high voltage ripple can damage a system and reduces the efficiency also increases the losses of the system. DC voltage of the PV output shown in figure 9.

For reduction of this ripple and increase the dc voltage required a DC-DC boost converter. Output voltage of DC-DC boost converter is ripple free and high voltage as 400V so it can be easily connected to the single-phase grid by using inverter. This DC-DC boost converter also useful for MPPT (Maximum Power point tracking) which is performed by perturb and observe method. This converter worked as a first stage of our system and work on a 5KHz Switching frequency. Output voltage of the first stage as a DC-DC boost converter is shown in figure 10 its shows the dc output voltage of the cascaded PV module.

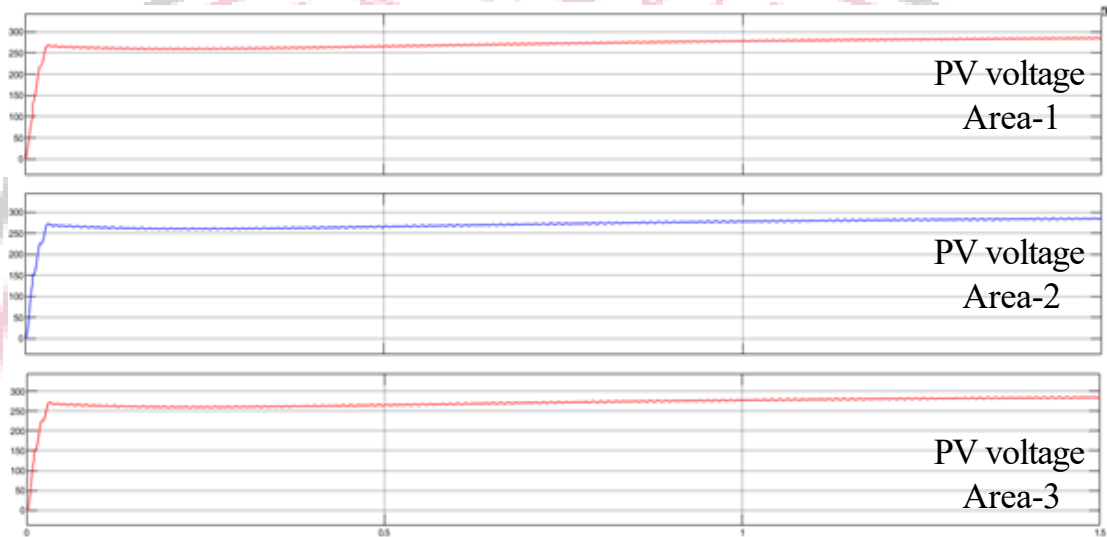

Figure 10: DC-DC boost converter output voltage through different area

Generating power from the different areas through renewable energy sources (RES) need to utilize power or store in a battery or transmit to the different areas by using grid connected system. Figure 11 shows the DC load current which is utilized as a DC load after the first stage.

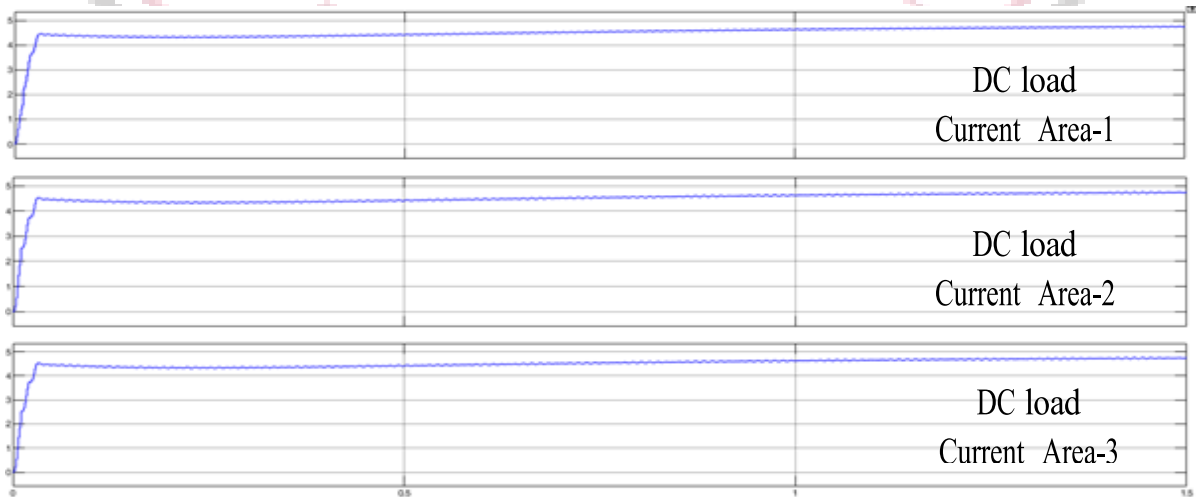

Figure 11: DC output load current through different area

For connection of renewable energy source to the grid required a power electronics converter. PV system generates a power in a form of DC so here required an inverter which is convert this dc power to the leveled AC power. It is a second stage of the proposed system in this stage convert DC voltage into the leveled AC voltage and cascaded T-type inverter used in this stage. By using of single T-type inverter generates a three-level at the output although cascaded of three modules through T-type inverter generates seven-level at the point of leveled AC output. Working of the proposed T-type converter is described in a previous chapter.

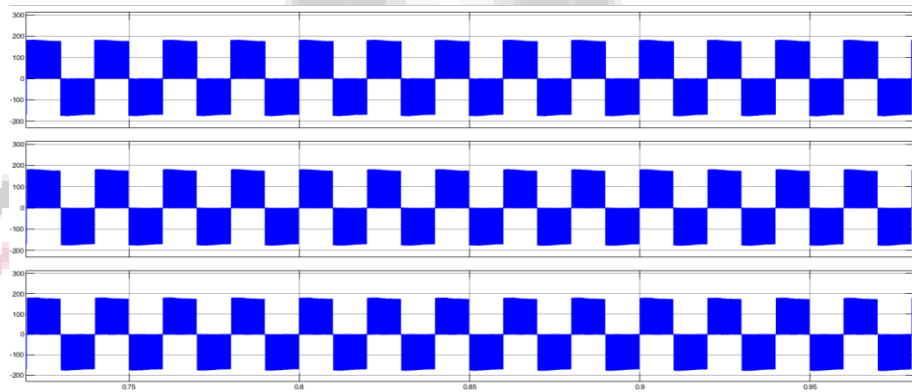

Figure 12: Three-level output voltage of the T-type inverter for module-1, module-2 and module-3

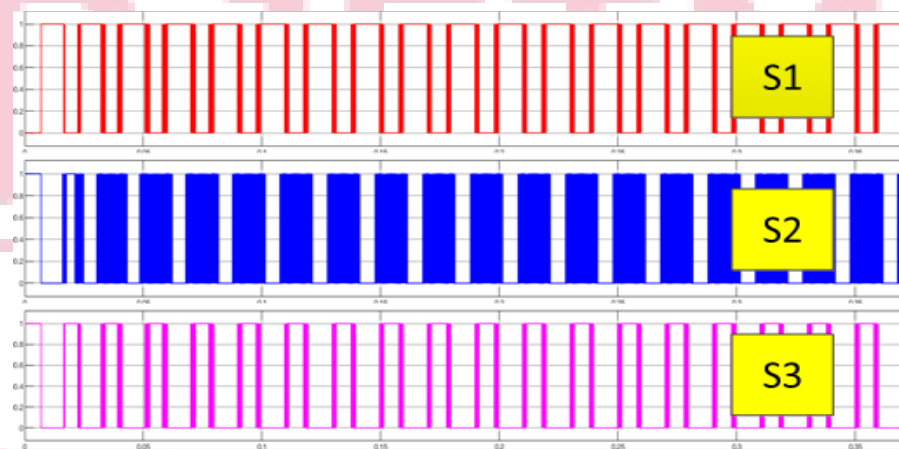

Figure 13: PWM switching gate signals

6. Conclusion

Modeling of photovoltaic array based on a simplified single diode model is depicted. The performance of the developed mathematical model is tested using MATLAB/SIMULINK. The developed PV model and actual model is compared.

The presented research work has been focused on the construction of variable amplitude sinusoidal voltage using the different topologies. The first effort has been related to the development of new MLI topology using diodes and switching devices under symmetric and asymmetric mode. The advantage of the topology articulates any desired voltage level with a reduced total number of devices and sources over basic and similar topology. The reduced stress of the sources achieved through pulse swapping among the cell switches, balances the load power and reduces the

voltage stress of the devices.

The current work deals with the change in irradiance and temperature of PV panel whereas this could also be extended by adding essential variables like partial shading parameter etc. The seven level boost ANPC inverter with PV panel is implemented with a single phase stand-alone load and it could also be implemented in online grid connected power system. In the future extension of the work, the number of switches used in the QZSI could be optimized.

REFERENCES

- [1] Prateek Sharma, Abhishek Misra and Ravi Shankar, "Impact of Renewable Sources in AGC for Two Area Interconnected Power System", IEEE 2020.
- [2] AbderezakLashab, Dezso Sera , Frederik Hahn , Luis Camurca, YacineTerriche, Marco Liserre, and Josep M. Guerrero, "Cascaded Multilevel PV Inverter With Improved Harmonic Performance During Power Imbalance Between Power Cells", IEEE Transactions on Industry Applications, Vol. 56, No. 3, May/June 2020.
- [3] A. Lashab D. Sera and J. M. Guerrero "Harmonics mitigation in cascaded multilevel PV inverters during power imbalance between cells" Proc. IEEE Int. Conf. Environ. Elect. Eng. IEEE Ind. Commercial Power Syst. Eur. pp. 1 -6 2019.
- [4] Q. Huang A. Q. Huang R. Yu P. Liu and W. Yu "High-efficiency and high-density single-phase dual-mode cascaded buck–boost multilevel transformerlesspv inverter with GaN AC switches" IEEE Trans. Power Electron. vol. 34 no. 8 pp. 7474-7488 Aug. 2019.
- [5] M. Abarzadeh and K. Al-Haddad, "An improved active-neutral-pointclamped converter with new modulation method for ground power unit application," IEEE Trans. Ind. Electron., vol. 66, no. 1, pp. 203–214, Jan. 2019.
- [6] A. Lashab D. Sera J. Martins and J. M. Guerrero "Multilevel dc-link converter-based photovoltaic system with integrated energy storage" Proc. 5th Int. Symp. Environ.-Friendly Energies Appl. pp. 1-6 2018.
- [7] C. Wang K. Zhang J. Xiong Y. Xue and W. Liu "An efficient modulation strategy for cascaded photovoltaic systems suffering from module mismatch" IEEE J. Emerg. Sel. Topics Power Electron. vol. 6 no. 2 pp. 941-954 Jun. 2018.
- [8] Y. P. Siwakoti, "A new six-switch five-level boost-active neutral point clamped (5L-Boost-ANPC) inverter," in Proc. IEEE Appl. Power Electron. Conf. Expo., 2018, pp. 2424–2430.
- [9] A. K. Yadav, M. Boby, S. K. Pramanick, K. Gopakumar, L. Umanand, and L. G. Franquelo, "Generation of high-resolution 12-sided voltage space vector structure using low-voltage stacked and cascaded basic inverter cells," IEEE Trans. Power Electron., vol. 33, no. 9, pp. 7349–7358, Sep. 2018.
- [10] W. Li, J. Hu, S. Hu, H. Yang, H. Yang, and X. He, "Capacitor voltage balance control of five-level modular composited converter with hybrid space vector modulation," IEEE Trans. Power Electron., vol. 33, no. 7, pp. 5629–5640, Jul. 2018.
- [11] D. Cui and Q. Ge, "A novel hybrid voltage balance method for five-level diode-clamped converters," IEEE Trans. Ind. Electron., vol. 65, no. 8, pp. 6020–6031, Aug. 2018.
- [12] W. Sheng and Q. Ge, "A novel seven-level ANPC converter topology and its commutating strategies," IEEE Trans. Power Electron., vol. 33, no. 9, pp. 7496–7509, Sep. 2018.
- [13] H. Tian, Y. Li, and Y. W. Li, "A novel seven-level-hybrid clamped (HC) topology for medium-voltage motor drives," IEEE Trans. Power Electron., vol. 33, no. 7, pp. 5543–5547, Jul. 2018.
- [14] Y. P. Siwakoti and F. Blaabjerg, "Common-ground-type transformerless inverters for single-phase solar photovoltaic systems," IEEE Trans. Ind. Electron., vol. 65, no. 3, pp. 2100–2111, Mar. 2018.
- [15] N. D. Dao and D.-C. Lee, "Operation and control scheme of a five-level hybrid inverter for medium-voltage motor drives," IEEE Trans. Power Electron., vol. 33, no. 12, pp. 10178–10187, Dec. 2018.